

Course: 3D Design
Title: Loft Modeling – Sword
Dropbox File: Sword.zip
Blender: Version 2.41
Level: Beginning
Author: Neal Hirsig (nhirsig@tufts.edu)

Loft Modeling – Sword



In this tutorial, we'll create a sword model using Blender's Lofting function.

Open MyBlender.blend (or the default if you are using MyBlender as the default Blender file).

We will begin by modeling the hilt. We will use the Default Cube Object for this object. Select the Default cube in Object Mode. In the Transform Properties Panel on the right change the Size X: to 4, Size Y to 1 and Size Z to 1.5

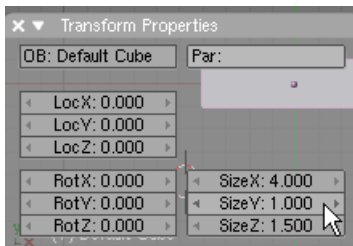

TAB to Edit Mode. In the Mesh Tools Panel press the Subdivide button Twice.

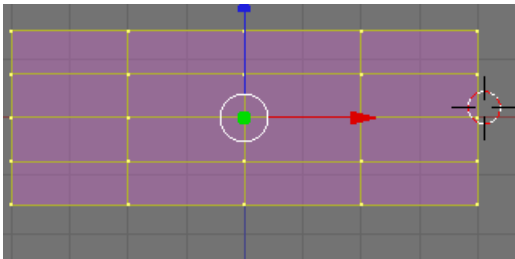
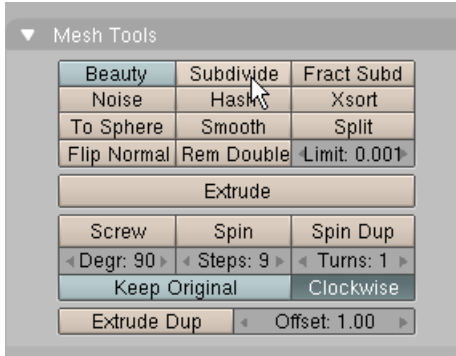

TAB out of Edit Mode.

In Top View place your 3D cursor to left of the default cube. Press Space / Add / Mesh / Cube. In the Mesh Tools Panel press the Subdivide button once.

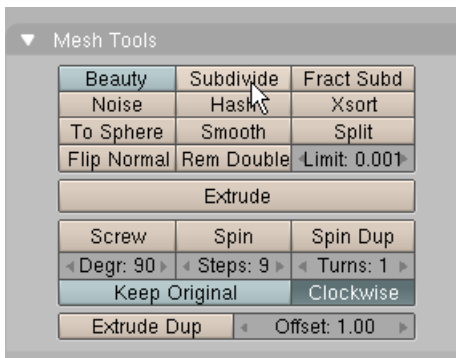

Switch to Left Side View (CTRL-NUM3). Press the AKEY to deselect the vertices. Select the center vertex.

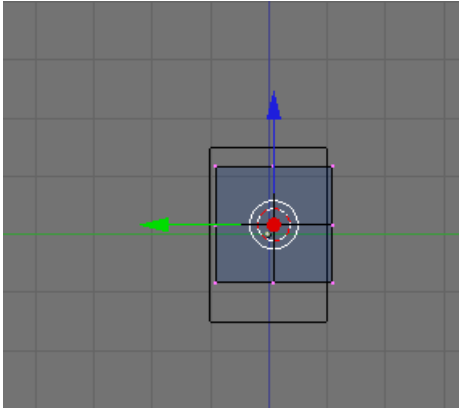

Switch to Front View. Use the Red Transform Widget Arrow and move the vertex out to the left as shown.

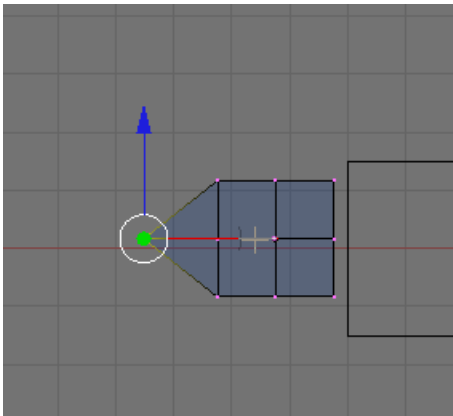

TAB out of Edit Mode. In the Transform Properties Panel Change the Size Y to 1.1, Size Z to 1.6

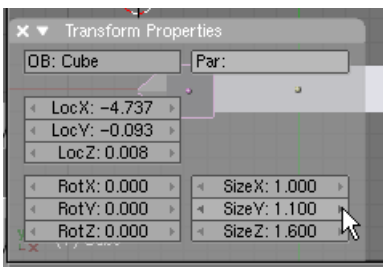

Use the Transform Widget to move the second cube into position (centered on the first) cube as shown below.

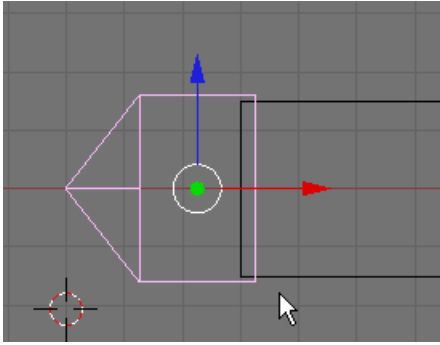

In the Mesh Panel press the Center New button to create a new center for the mesh object.

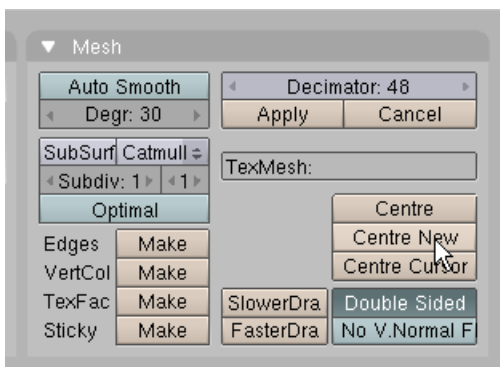

Press SHIFT-D (Duplicate). Move the duplicate to the other side of the cube. Press the RKEY to revolve it 180 degrees and use the Transform Widget to position it as shown.

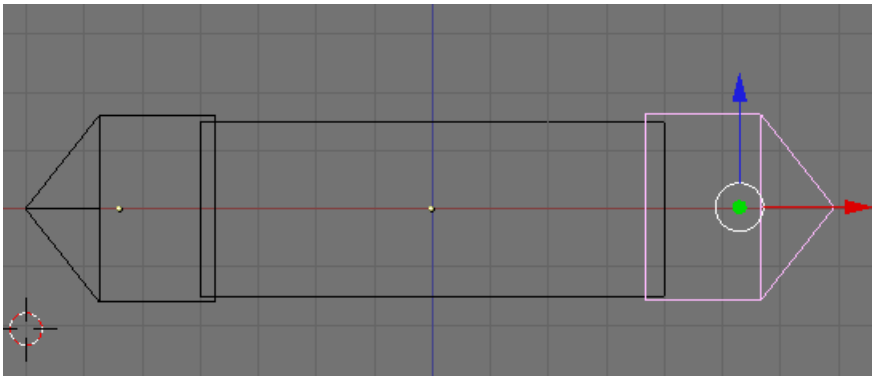

Switch to Top View. Move the two end pieces so they are centered on the middle piece as shown.



Press the **A**KEY to deselect any objects. Place your 3D cursor in the center of the model. Press Space / Add / Mesh / Cube. **TAB out of Edit Mode**. In the Transform Properties Panel set the Size X to 2.

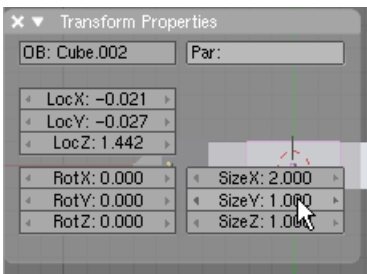

Switch to Front View and In the Mesh Panel press the Center New button.

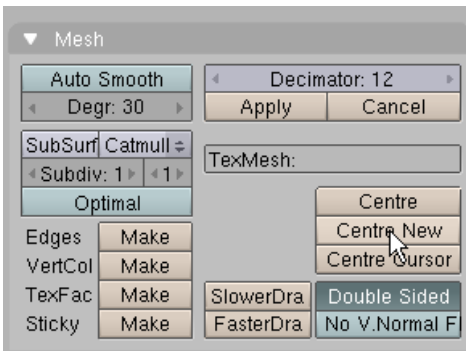

Move the cube down to the center of the model as shown.

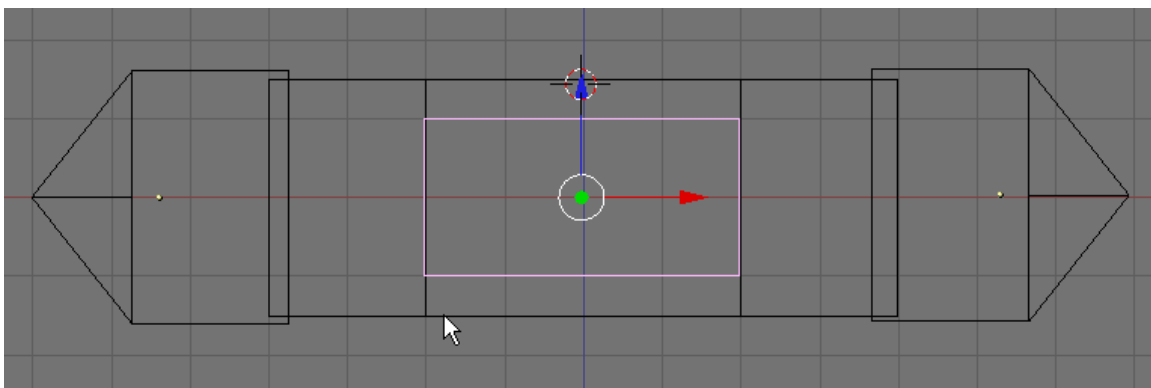

Switch to Top View. Move the cub to the edge of the center piece as shown.

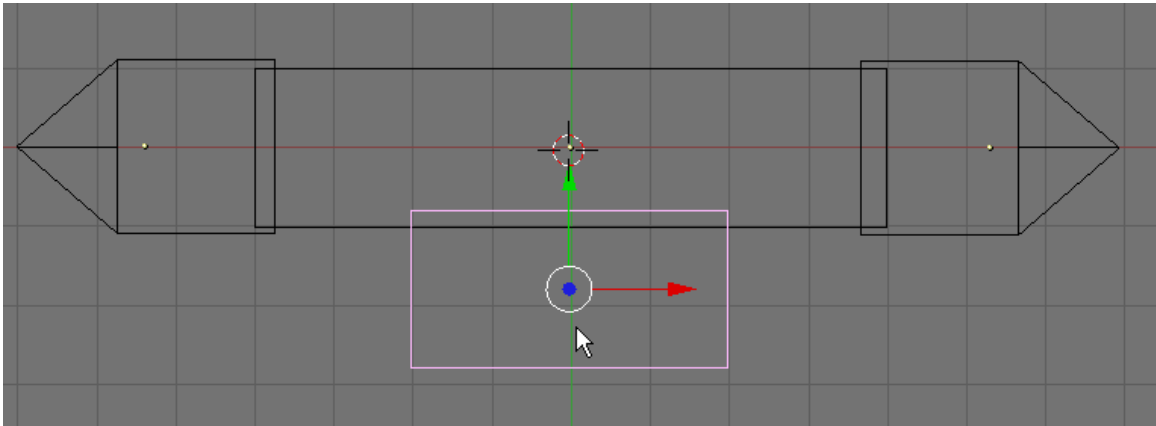

TAB to Edit Mode. Press the AKEY to deselect the vertices. Box Select (BKEY) the bottom vertices as shown.

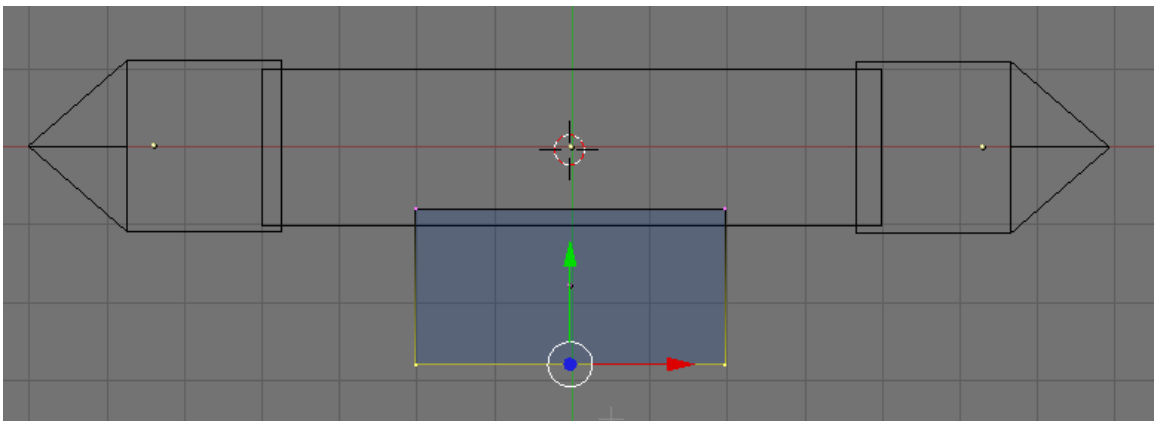

Switch to Side View. Use the Green Transform Widget Arrow to move the vertices out to the left as shown.

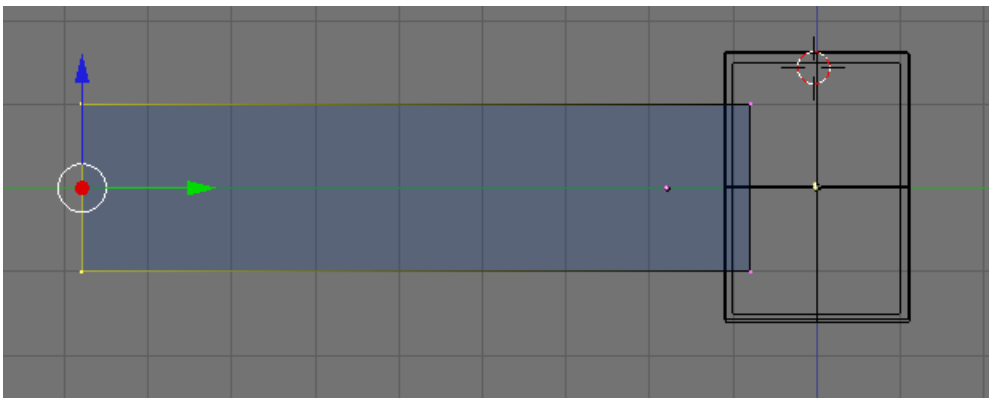

Switch to Front View. Press the SKEY and scale the end vertices down as shown.

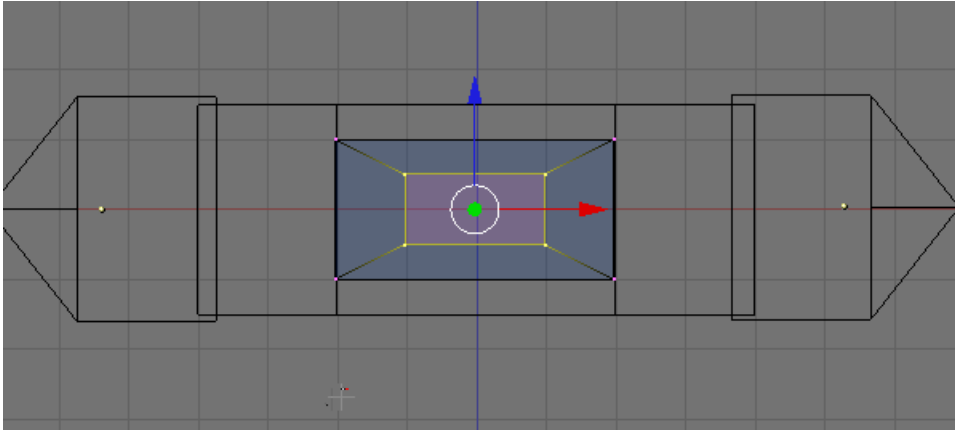

Press the AKEY twice to **select all of the vertices**. Switch to top view. Press the Subdivide button Three times.

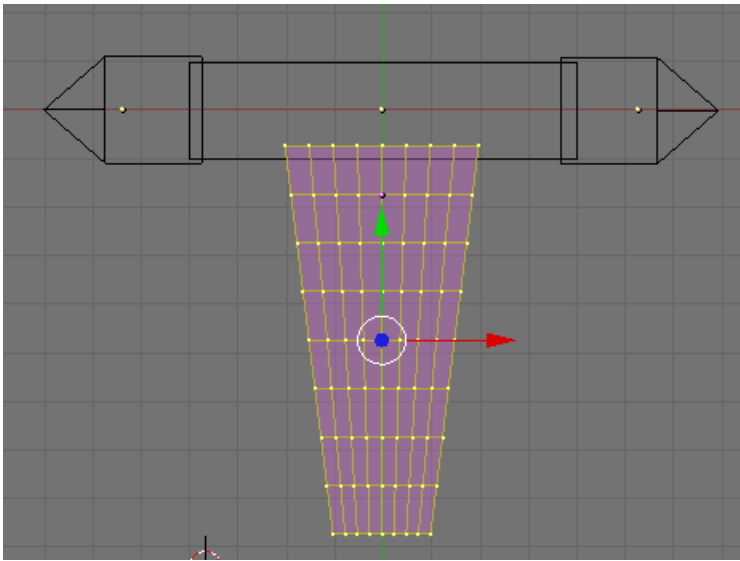

TAB out of Edit Mode. Press the Center New button. Place your 3D cursor at the end of the hilt as shown.

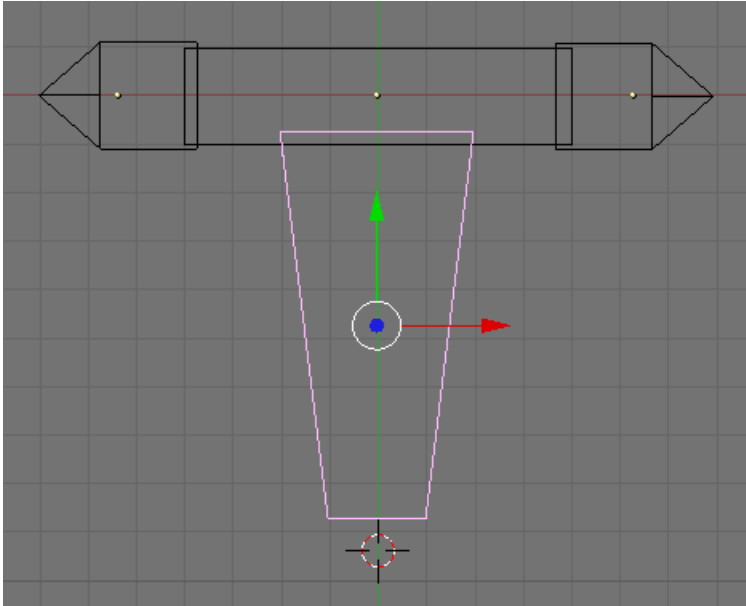

Press Space / Add / Mesh / UV Sphere. Scale it down and position it as shown.

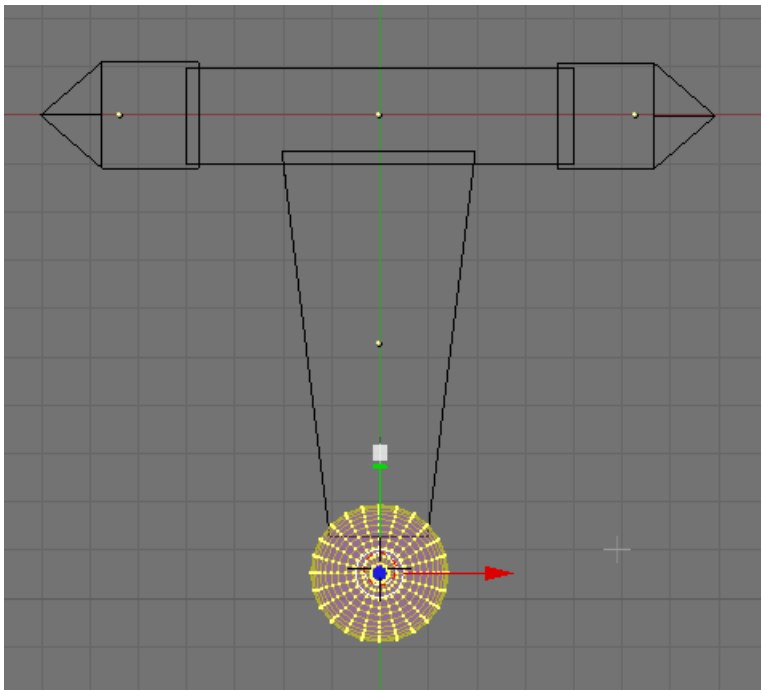

Switch to Side View. Move the sphere up to the hilt as shown.

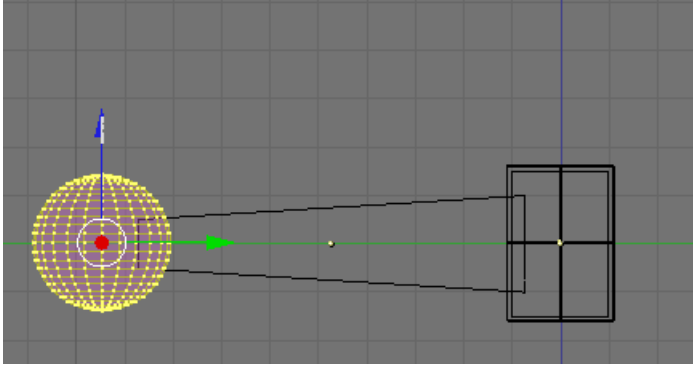

TAB out of Edit Mode. Press the Center New button. Switch to top view. Select the handle and the crosspiece as shown.

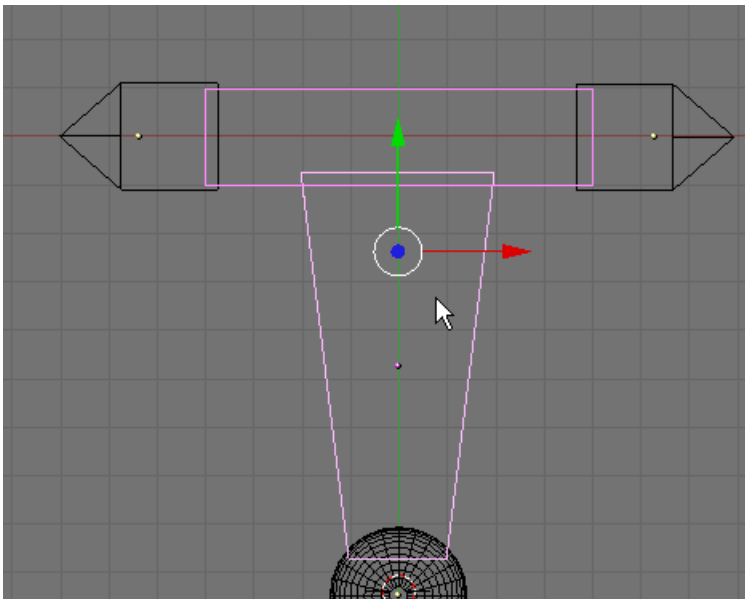

Press CTRL-J and join the 2 objects together. In the Transform Properties Panel name this object Hilt.

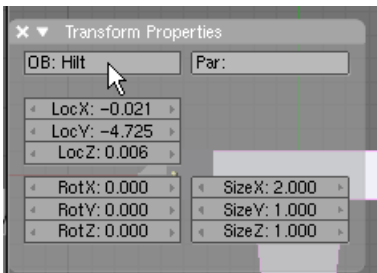

Select the sphere only. In the Transform Properties name this object Hilt Ball.

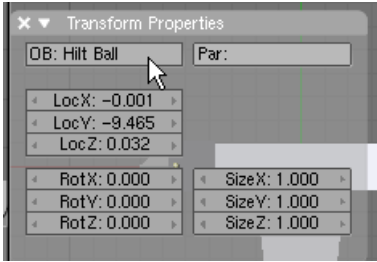

In the Link and Materials Panel press the Set Smooth button.

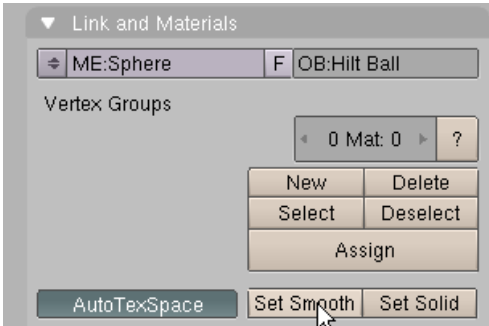

Select the left pointed cube. Name this object Left End Cap. Select the Right pointed cube. Name this object Right End Cap.

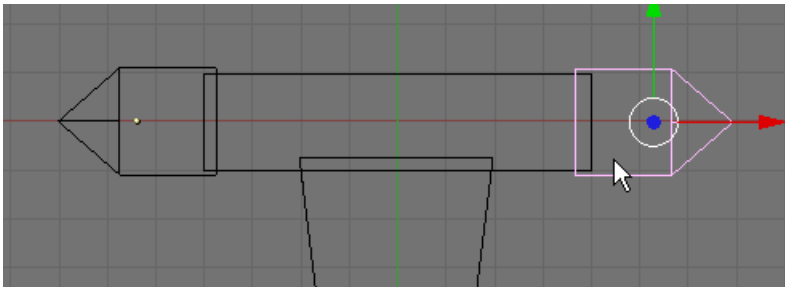

Save your file F2.

Press the AKEY to deselect any objects. Switch to Rear View (CTRL-1). Place your 3D cursor in the center of the Hilt. Press Space / Add / Curve / Bezier Circle.

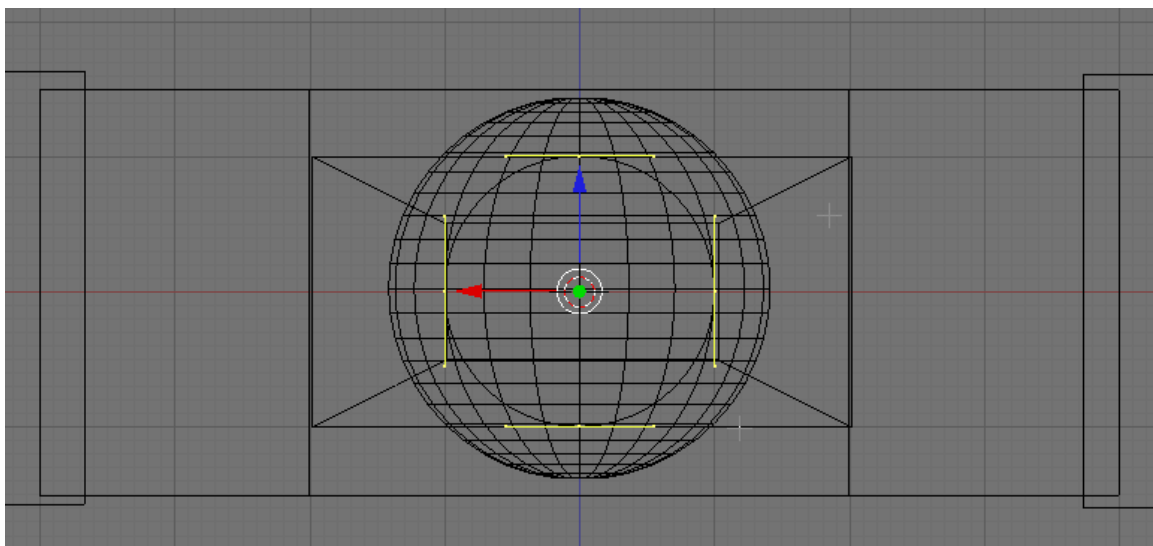
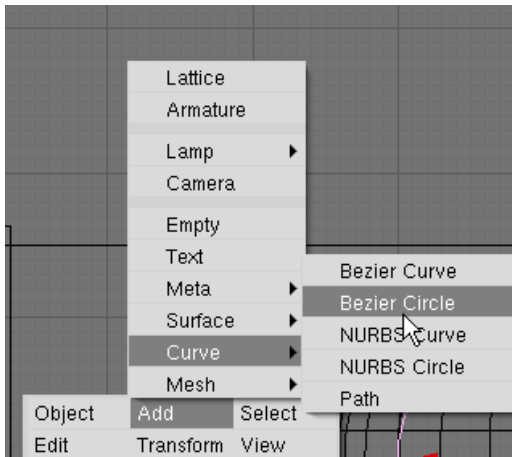

Select the right vertex and move it as shown below. Select the left vertex and move it as shown below.

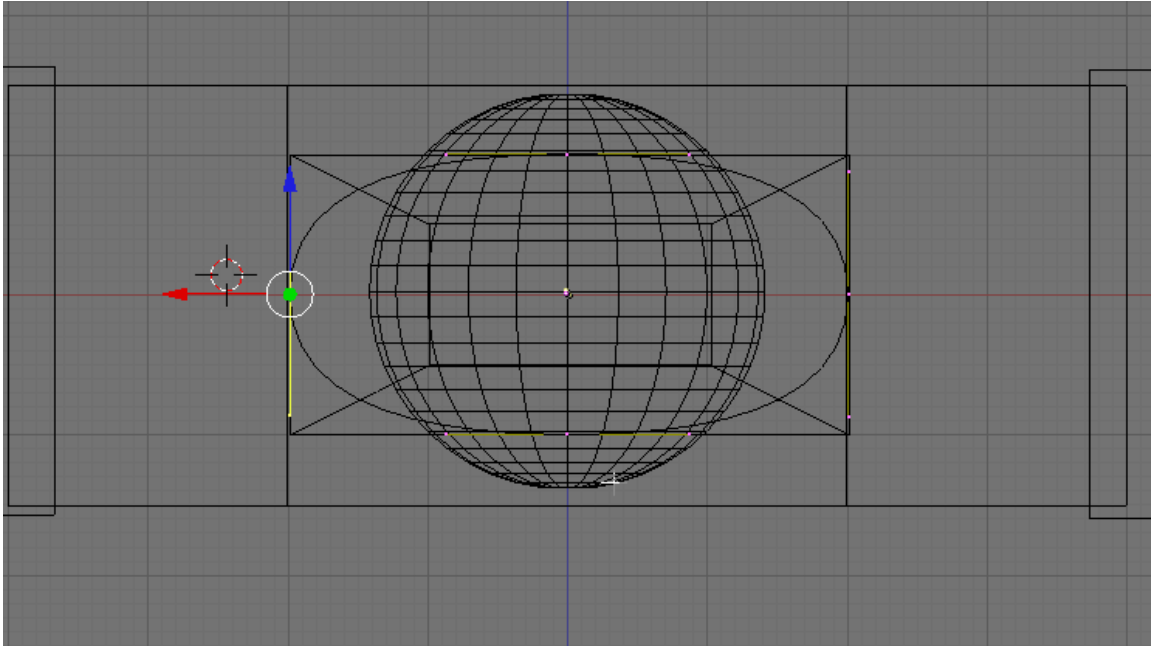

Press the AKEY (Twice) to select all of the circle's vertices. The handles of the Bezier vertices for a Bezier circle are by default set to "Auto". That is, each handle has a completely automatic length and direction, set by Blender to ensure the smoothest result. We want our object to have straight lines. Press the VKEY (Vector). This changes the Bezier handles to "Vector" mode in which both parts of the handle always point to the previous handle or the next handle forming straight lines.

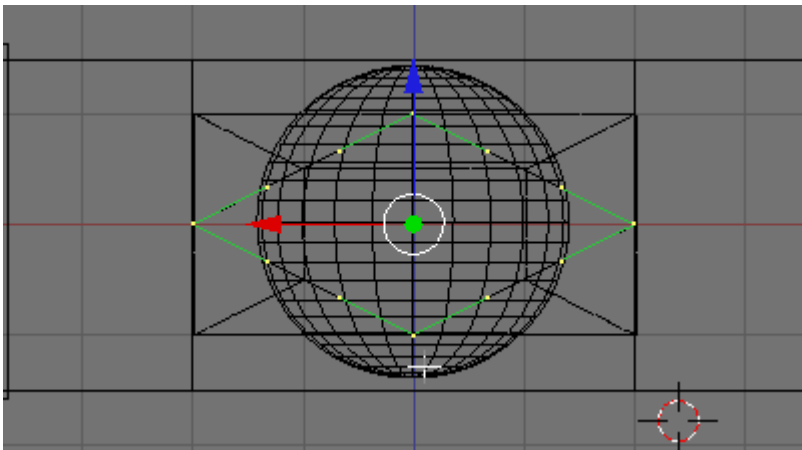

In the Transform Properties Panel name this shape Blade Shape.



We will be lofting this shape along a straight path to form the blade of the sword. To do this the lofted shape **MUST** have a name.

TAB to exit Edit Mode. Switch to side view and place your 3D cursor to the right of the Hilt object.

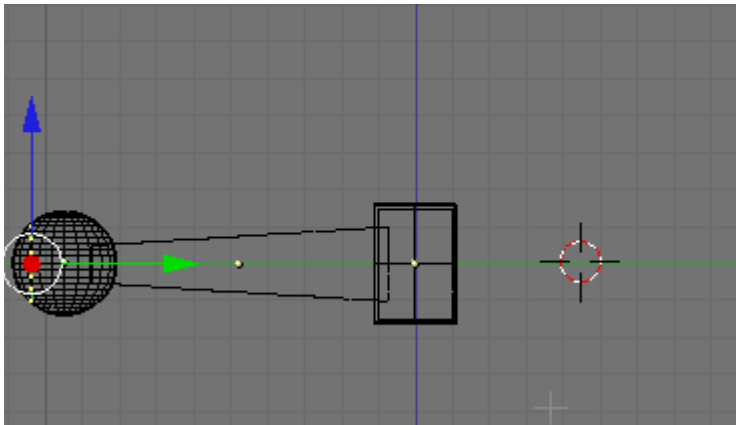

Press Space / Add / Curve / Bezier Curve.

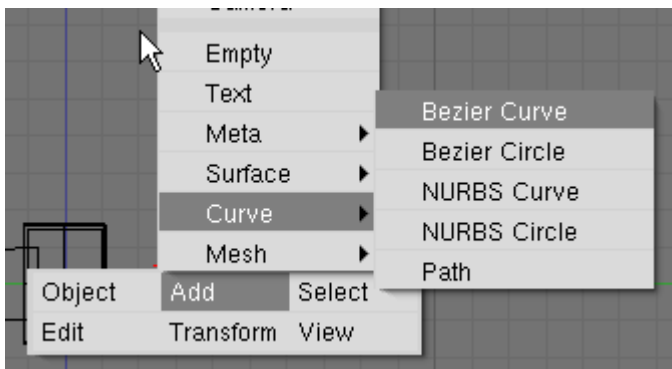

This places a Bezier curve on the display with both end vertices selected in Edit Mode.

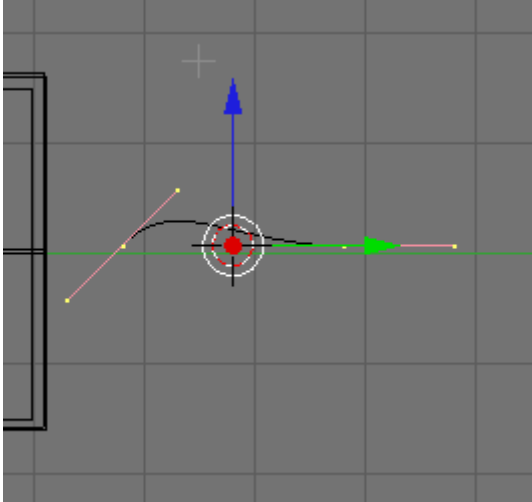

Press the VKEY to convert the Bezier handles to Vector mode. (forming a straight line.)

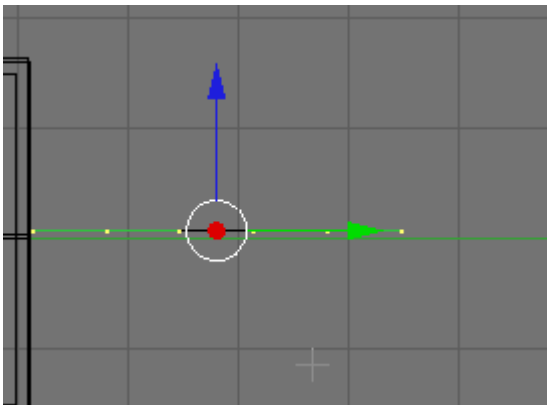

Press the AKEY to deselect the vertices. RMB select the right vertex.

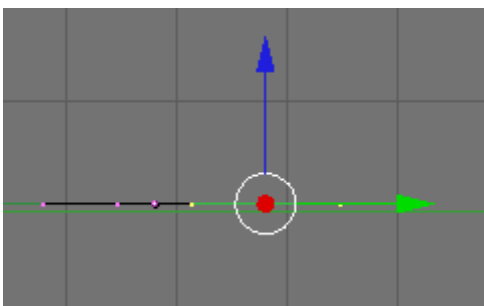

Zoom out a bit. Use the Green Transform Widget Arrow to move the vertex to the right the length of the sword blade as shown.

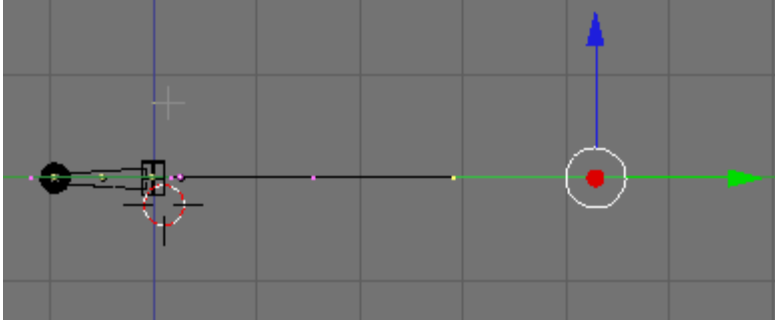

TAB out of Edit Mode. In the Curve and Surface Panel type in the name of the loft shape (Blade Shape) in the box marked BEVObj: then press Enter.

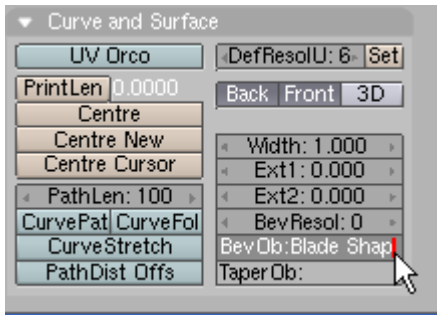

This will loft the Blade Shape curve object along the straight path.

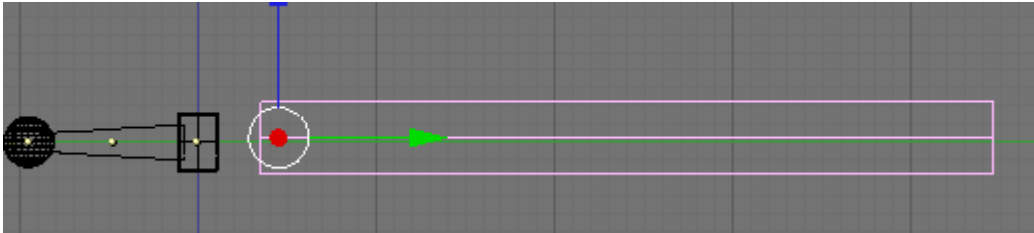

In the Transform Properties Panel name this object Blade.



Switch to Front view. Notice that the Blade object is rotated 90 degrees.

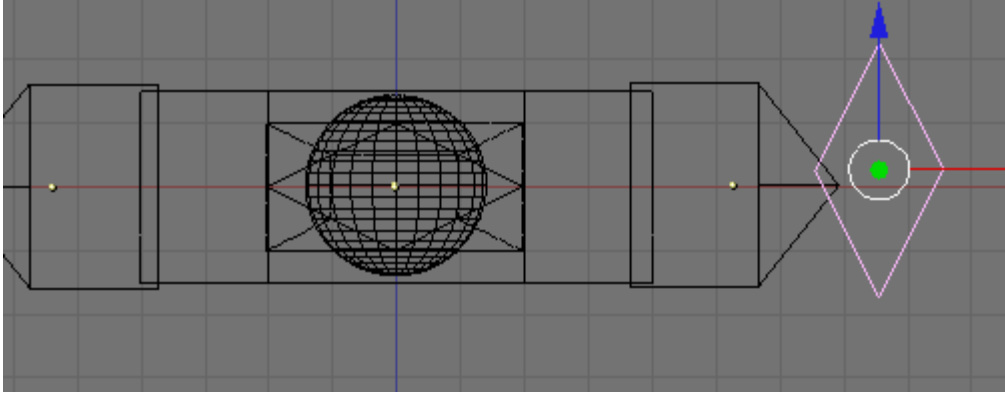

In the Transform Properties Panel set the ROT X to 0

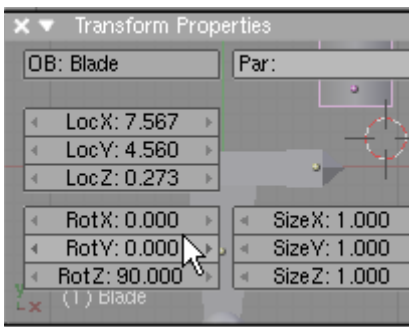

In the Front view, using the Transform Widget Arrows move the Blade into its proper position as shown.

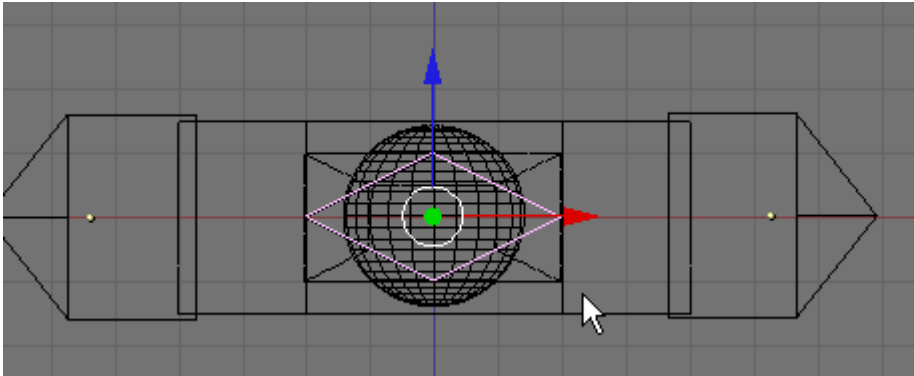

Switch to side View and Move the Blade into position as shown.

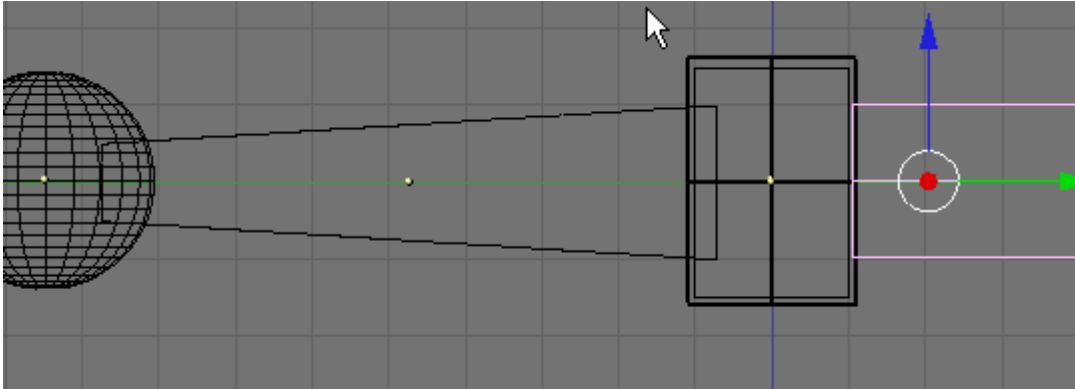

Press ALT-C and convert the Lofted Blade object to a Mesh object.



TAB to Edit Mode. Press the BKEY and Box select the rightmost vertices.

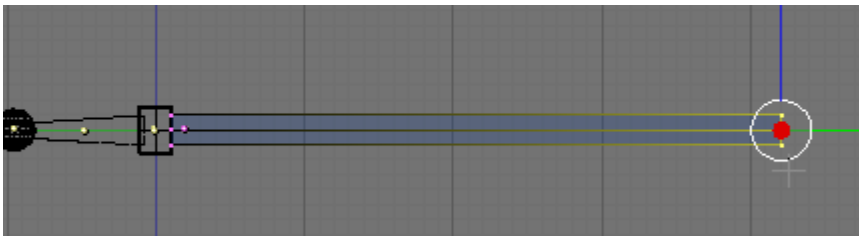

Switch to Front View. Press the SKEY (Scale) and scale the vertices down to a point as shown.

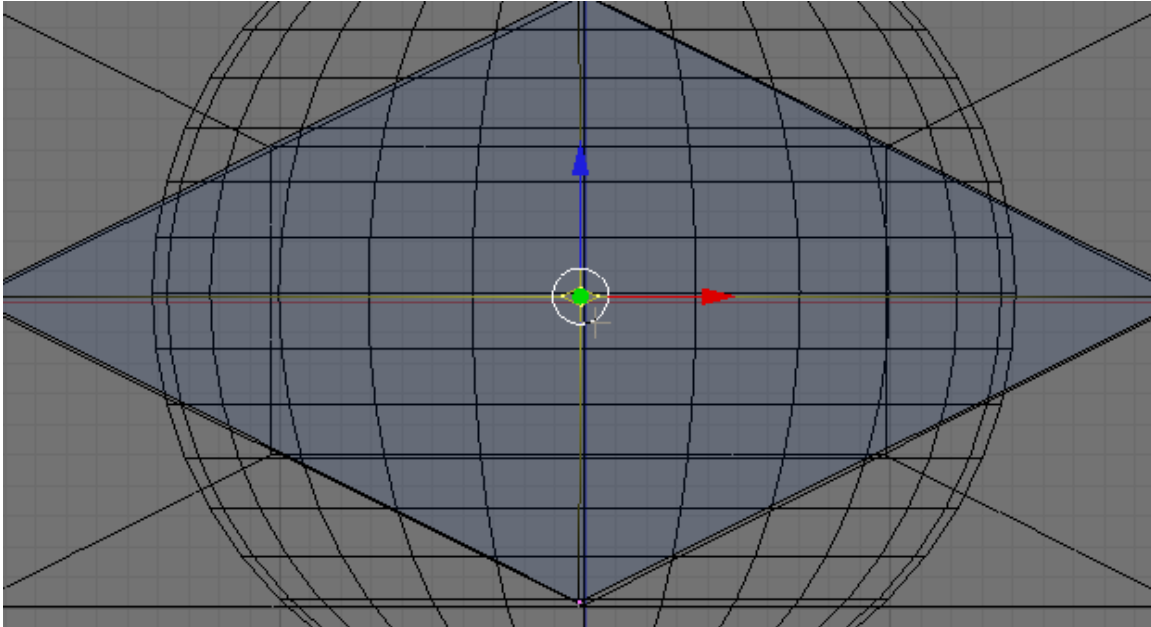

Press the AKEY (Twice) to select all of the Blade's vertices. Switch to side View and Zoom out a bit. In the Mesh Tools Panel press the Subdivide button **4 Times**.

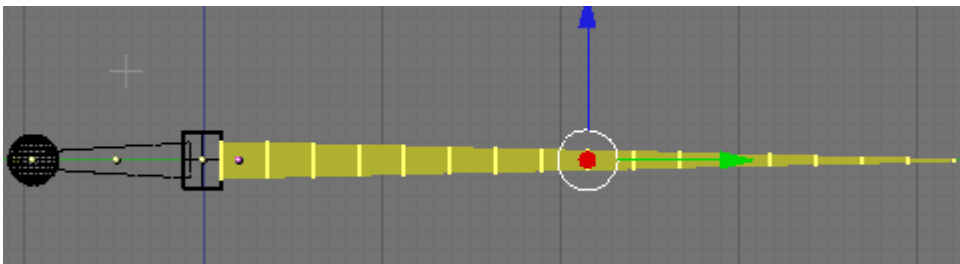
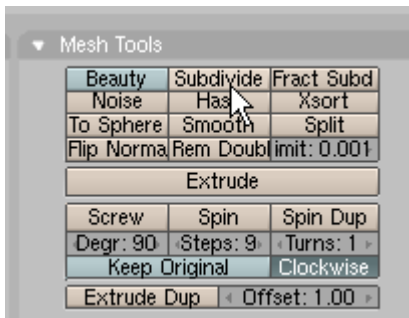

Press the AKEY to deselect the vertices. TAB out of Edit Mode. Switch to Top View. With the Blade still selected SHIFT select the Left End Cap (adding it to the selection), SHIFT select the Right End Cap (adding it to the selection), SHIFT select the Hilt Ball (adding it to the selection) then SHIFT select the Hilt object making it the last object added to the selection). Press CTRL-P and choose Make Parent. The Hilt is now the Parent of the other objects.

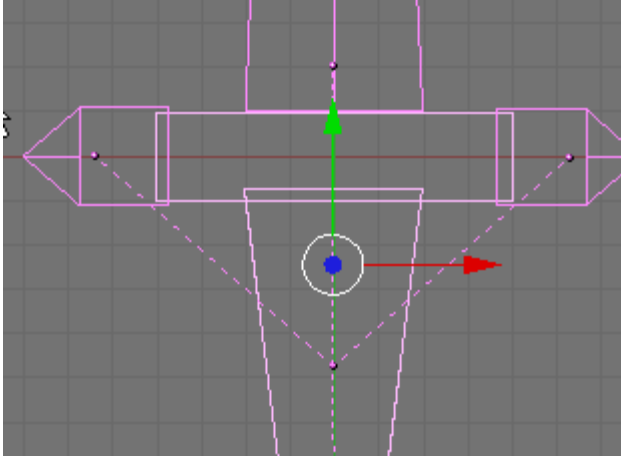

Switch to Front View. Select the Hilt object alone. In the Transform Properties Panel Set the ROT X to 90 and the ROT Y to 40. This will make the sword face the front view at an angle.

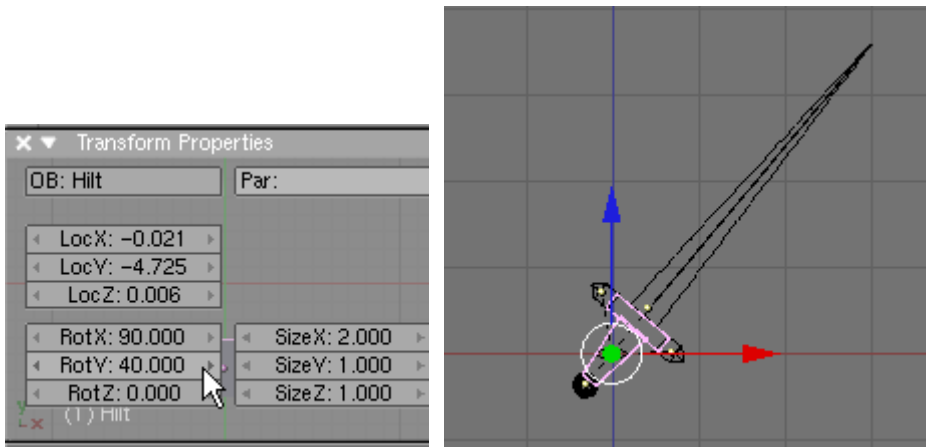

In the Outliner Panel select the Blade Shape object.

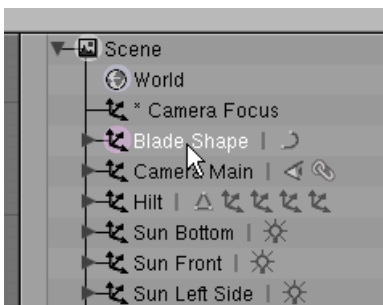

This is the object we used to loft along the Blade path. Press the delete button and delete it.

Save your file CTRL-W. We will now add some materials to the Sword. Select the Hilt Ball alone. Press F5 (Shading) and add a new Material. In the Texture Panel press Add New. Press F6 (Textures). In the Texture Type dropdown box choose Image.



In the Image Panel press Load Image. Select the GOLDFOIL.gif image, which is located in the Sword.zip file. After loading the image press the Materials sub menu button.

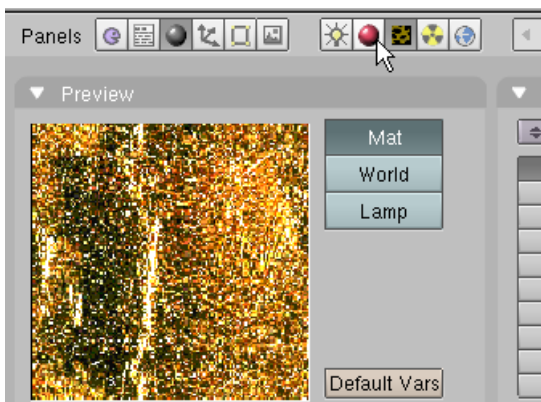

Press the Shaders tab. In the Shaders Panel set the Spec to 1 and the Hardness to 255.

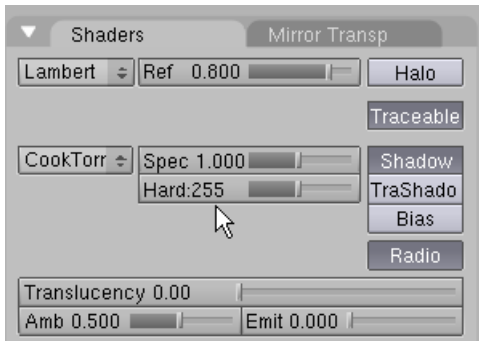

Press the Map Input tab on the far right. Select the Sphere Mapping.

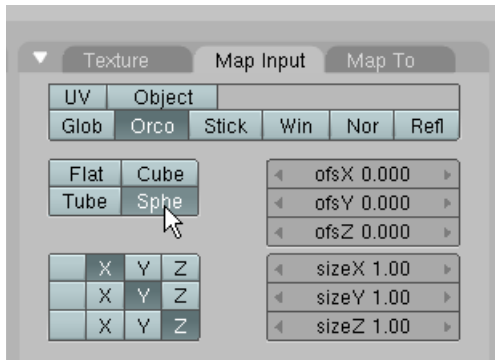

In the Materials Panel name this material Goldfoil.

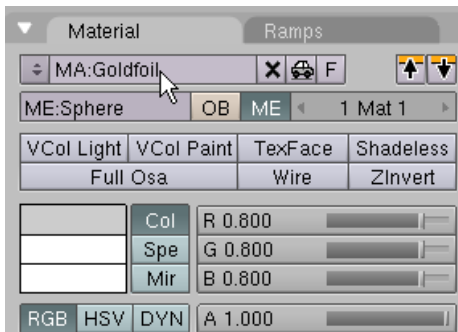

Select the Left End Cap alone. We will add a variation of the Goldfoil Material but since we will make changes from the last we must create a separate and new material. Press F5 (Shading) and add a new Material. In the Texture Panel press Add New. Press F6 (Textures). In the Texture Type dropdown box choose Image.



In the Image Panel press Load Image. Select the GOLDFOIL.gif image, which is located in the Sword.zip file. After loading the image press the Materials sub menu button.

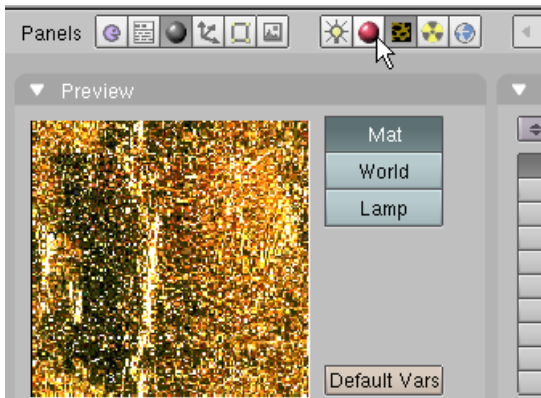

Press the Shaders tab. In the Shaders Panel set the Spec to 1.9 and the Hardness to 390.

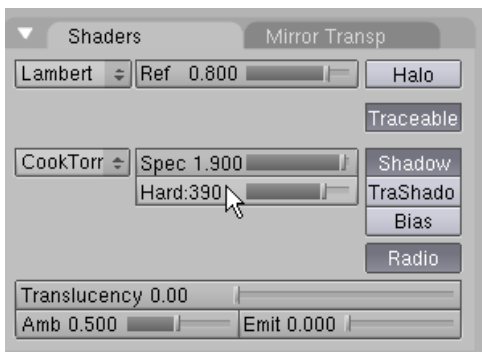

Press the Map Input tab on the far right. Select the Cube Mapping.

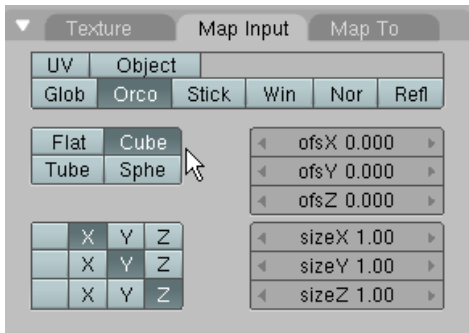

In the Materials Panel name this material Goldfoil #2

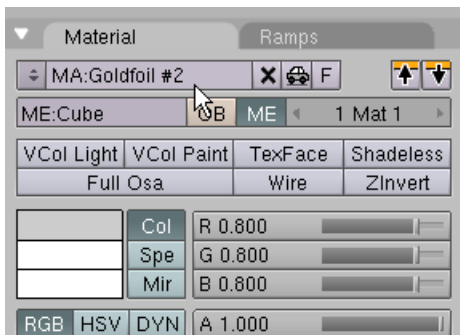

Select the Right End Cap. Press the icon to the left of the Add New button and select Goldfoil #2.

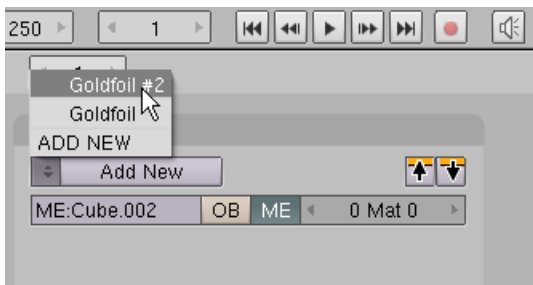

This applies the Goldfoil #2 material to the end cap with all of the same settings.

Select the Hilt alone. Press F5 (Shading) and add a new Material. In the Texture Panel press Add New. Press F6 (Textures). In the Texture Type dropdown box choose Image.

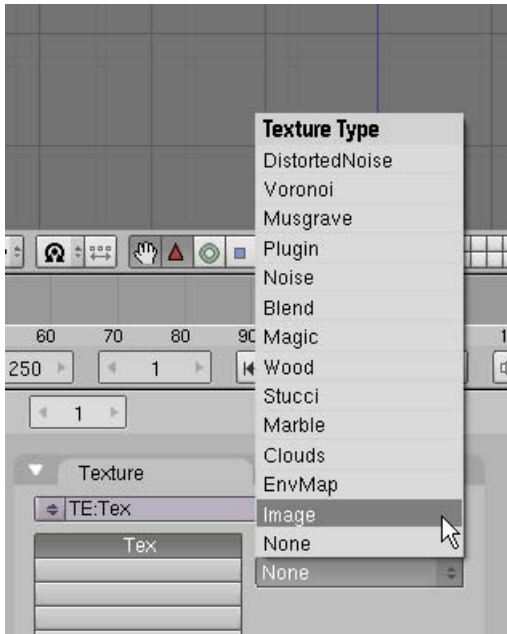

In the Image Panel press Load Image. Select the METAL15.JPG image, which is located in the Sword.zip file. After loading the image press the Materials sub menu button.

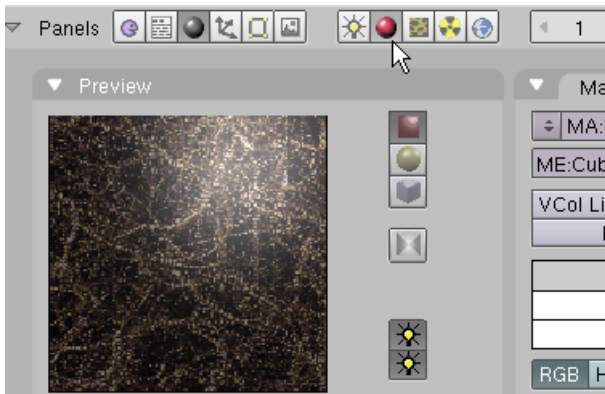

Press the Shaders tab. In the Shaders Panel set the Hardness to 211.



Press the Map Input tab on the far right. Select the Cube Mapping.

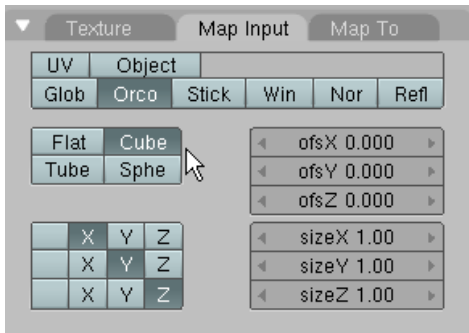

In the Materials Panel name this material Hilt Metal.

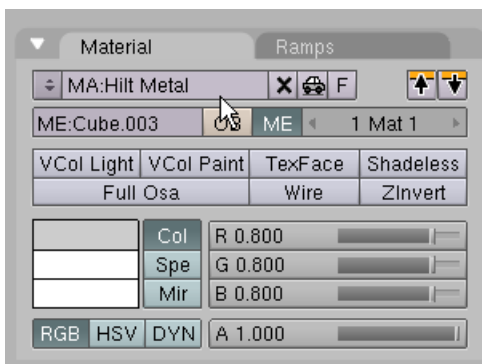

Select the Blade alone. Press F5 (Shading) and add a new Material. In the Texture Panel press Add New. Press F6 (Textures). In the Texture Type dropdown box choose Image.



In the Image Panel press Load Image. Select the STEELPLT.JPG image, which is located in the Sword.zip file. In the Image Panel set the Xrepeat to 6.

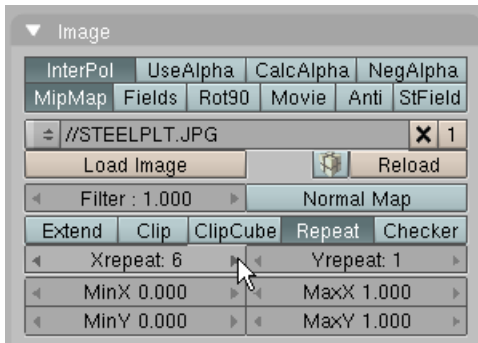

Press the Materials sub menu button.



Press the Shaders tab. In the Shaders Panel set the Spec to 1.2 and the Hardness to 192.

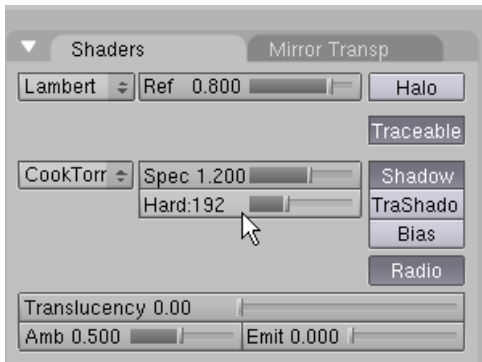

Press the Map Input tab on the far right. Make sure the mapping is set to the default Flat.

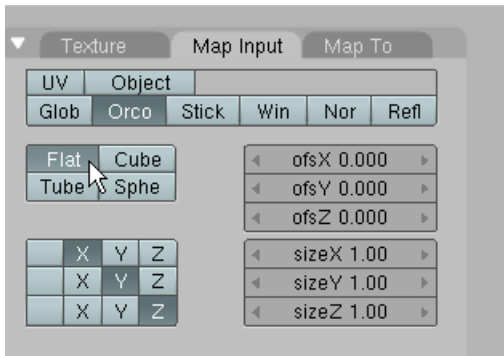

In the Materials Panel name this material Blade.

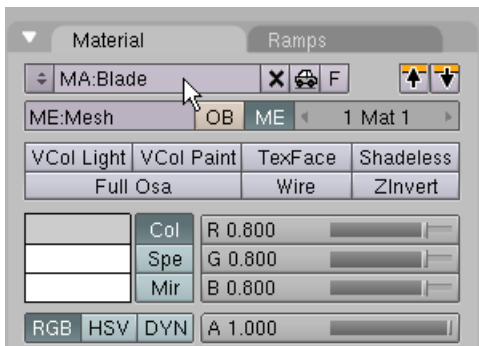

Save your file CTRL-W. Add Layer 10 (which contains the camera and the camera focus) to the scene. Switch the bottom right Perspective view to camera view (NUM0). Make sure the main 3D viewport is in Front View. Select the Camera focus from the outliner Window.

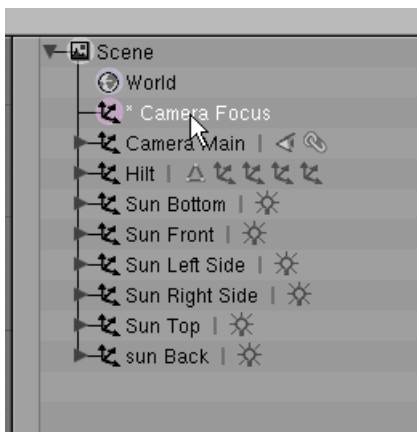

Press the GKEY (Grab) and position the camera focus object to the left of the sword as shown.

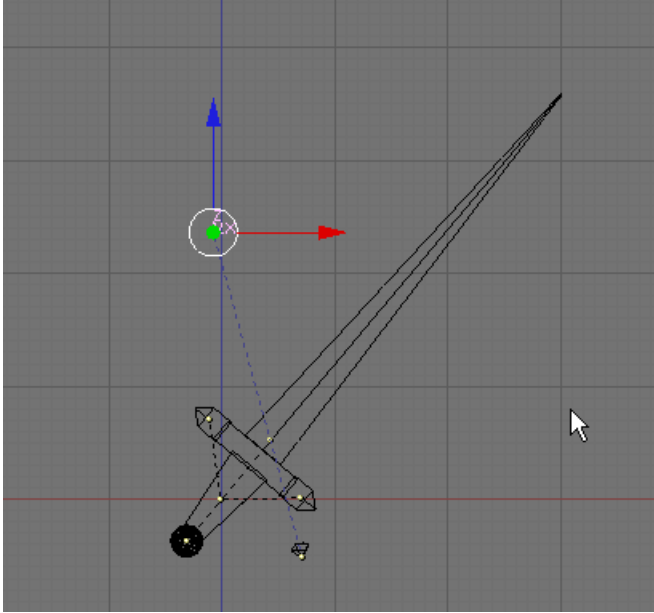

Select the camera object and using the top, front and side views locate the camera so that the camera view is similar to the one shown below (Note: you may have to adjust the camera focus object as well).

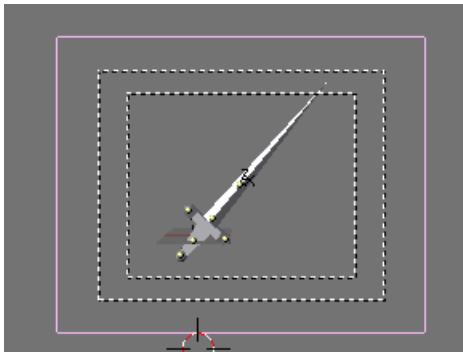

Add Layer 20 to the scene. This layer contains the lighting set-up.

Save your file CTRL-W. Press F10 (Scene).

Render F12.



You can save your rendering as an image file by pressing F3. Select the directory you want the image saved and name the file (you must add the .jpg file extension). Press Save JPEG when finished.



A finished copy of this tutorial file named SwordComplete.blend is located in the Sword.zip file.